

FORGINGS: CLOSED DIE TERMINOLOGY AND EQUIPMENT

eLearning courses designed to increase productivity and profits

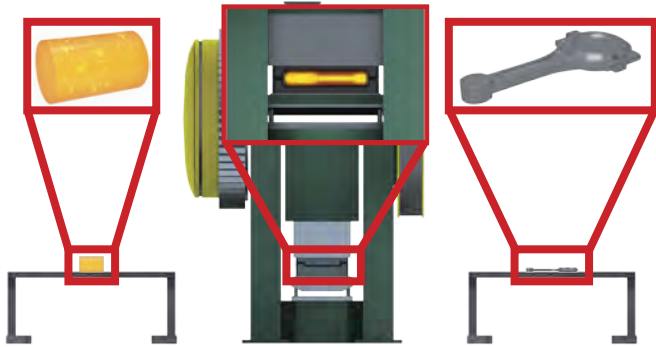

Learning made Simple, Visual, and Interactive

Forging: Closed Die Terminology and Equipment introduces learners to the basic equipment, concepts, and general terminology that are often applied for closed die forging industries. Developed with the help of subject matter experts, this course will give you the practical knowledge to work more efficiently with closed die forgings and the associated equipment.

Credit Hours **3**

Learning Objectives

- Recall some of the properties of forged material.
- Understand some common terms such as billet, blank, press, and die.
- Recognize the basic equipment and tools used in forging processes.
- Identify the different types of impression dies that are commonly used.
- Recall some of the basic forging design considerations.

Table of Contents

I. Forging Basics and Terminology

- Basic Terminology
- Properties of Forged Material
 - o Mechanical Properties
 - o Grain Structure
 - o Increased Density
- Forgeability
 - o Strain Rate
- Other Common Forging Processes
 - o Open Die Forging
 - o Ring Rolling
 - o Powder Forging
 - o Rotary Forging
 - o Radial Forging
 - o Upset Forging

- Forging Temperature Range
 - o Hot Forging
 - o Warm Forging
 - o Cold Forging
- Stages of Impression Die Forging
- Net, Near Net, and Conventional Forgings

• Impression Dies

- o Forging Drawing Example
- o Forging Design Considerations
- o Impression Die Cavities
- o Impression Die Material
- o Impression Die Manufacturing

II. Forging Equipment and Tooling

- Forging Presses
 - o Types of Force
 - o Mechanisms
- Forging Hammers
 - o Gravity Drop Hammers
 - o Power Drop Hammers
 - o Counterblow Hammers

