

# ENGINEERING DRAWINGS FUNDAMENTALS [3RD ED.]

*eLearning courses designed to increase productivity and profits*

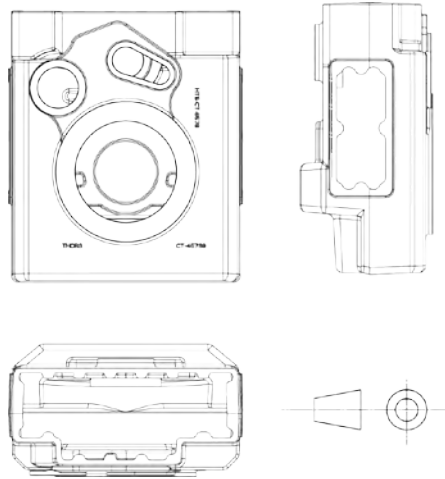

## Learning made Simple, Visual, and Interactive

Engineering Drawings Fundamentals [3rd Ed.] introduces the fundamental concepts that are required to read, understand, and interpret engineering drawings used throughout the manufacturing industry. Presented in THORS' highly visual and interactive learning format with many examples, this course assists learners in understanding and interpreting the views, different elements, and dimensioning methods used on engineering drawings.

Credit Hours **4**

## Learning Objectives

- Interpret the graphic language used in mechanical drawings for practical applications.
- Locate the title block, revision block, and drawing zone on a print.
- Distinguish between different views used to represent an object on a drawing.
- Identify and understand the meaning behind the diverse elements of a drawing, which includes lines, symbols, and dimensioning types and methods.
- Verify knowledge retention by reviewing complete drawing examples for the elements and components discussed in the course.

## Table of Contents

### I. Drawing Template

- Title Block
- Revision Block
- Drawing Zone

### II. Part Views

- Orthographic View
- Axonometric View
- Section View

### III. Elements of a Drawing

- Lines
- Symbols
- Notes

### IV. Part Dimensioning

- Dimensioning Basics
- Dimensioning Types
- Dimensioning Methods

