

Centerless Grinding II

eLearning courses designed to increase productivity and profits

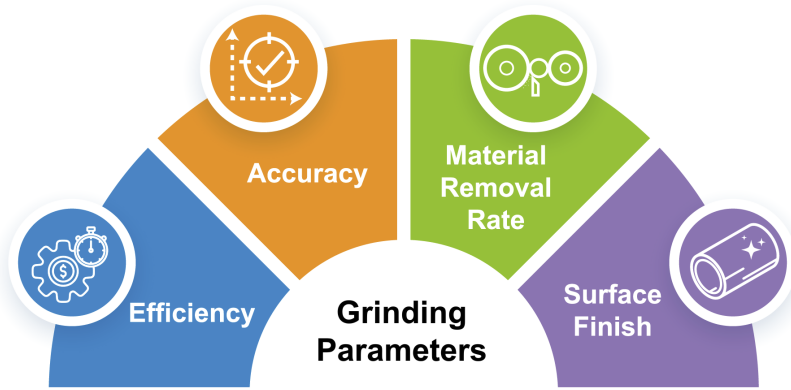

Learning made Simple, Visual, and Interactive

The THORS *Centerless Grinding II* course offers a detailed overview of grinding parameters, including the setup and adjustment of grinding and regulating wheels, workblade, and cutting parameters. It also covers various dressing tools and their respective parameters. Finally, the course explores the comprehensive setup of centerless grinding machines.

Learning Hours **1.5**

Learning Objectives

- Define grinding parameters and outline the key grinding wheel parameters.
- Understand the various dressers and their parameters for achieving effective wheel dressing.
- Learn the process of setting up a centerless grinding machine for proper operation.

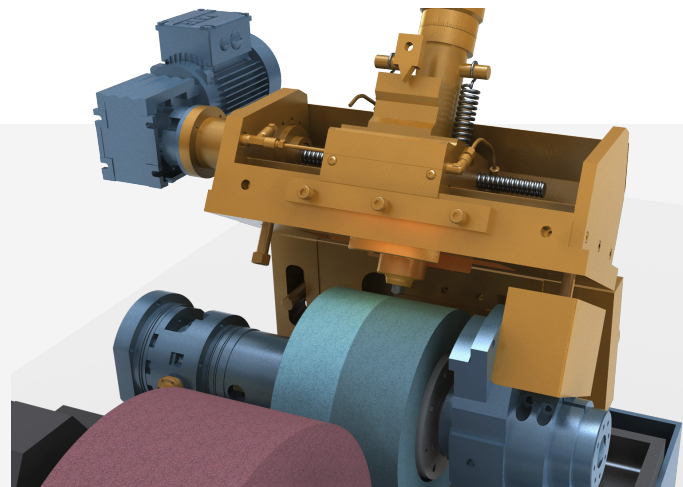

Table of Contents

I. What Are Grinding Parameters?

- Grinding Wheel Parameters
- Regulating Wheel Parameters
- Cutting Parameters
- Workblade Parameters

II. What Are Dressing Parameters?

- Dresser Types
- Fixed Dresser Parameters
- Rotary Dresser Common Parameters
- Rotary Dresser Specific Parameters

III. How Is a Centerless Grinding Machine Set Up?

- Grinding and Regulating Wheels Setup
- Workpiece Preparation and Workblade Positioning
- Coolant System Setup, Safety, and Parameter Adjustments

